



# FB1697-1 FLORENCE TOILET

Equipped with a 6 and 4 liters double flush system

## PRODUCT DESCRIPTION:

White porcelain  
 Contemporary style  
 Fully glazed trapway  
 One piece toilet  
 Integrated soft and removable close seat  
 1000 + grams



## BOX SIZE:

29 1/2" x 16" x 31"

## NET WEIGHT:

97 lbs

## GROSS WEIGHT:

102 lbs

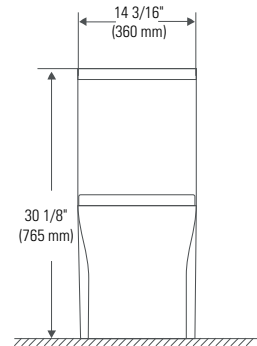
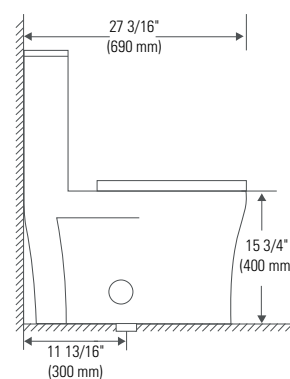
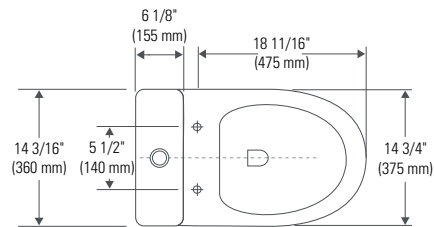

Meets Canadian Standards Association standard B651-04.

\*All dimensions are approximate and subject to change without notice. Please refer to the installation guide before beginning the installation.



**Certification ECORESPONSIBLE**  
 First manufacturer of bathroom products in North America to be certified ecoresponsible.



## Produits Neptune

6835, Picard street, Saint-Hyacinthe (Quebec) J2S 1H3

Phone: (450) 773-7058 - Fax: (450) 773-5063

produitsneptune.com

REV: 01-19



# FB1697 FLORENCE TOILET

Equipped with a 6 and 4 liters double flush system

## PRODUCT DESCRIPTION:

White porcelain  
 Contemporary style  
 With glazed trapway  
 One piece toilet  
 Integrated soft and removable close seat  
 1000 + grams



## BOX SIZE:

30" x 17" x 48"

## NET WEIGHT:

104 lbs

## GROSS WEIGHT:

106 lbs

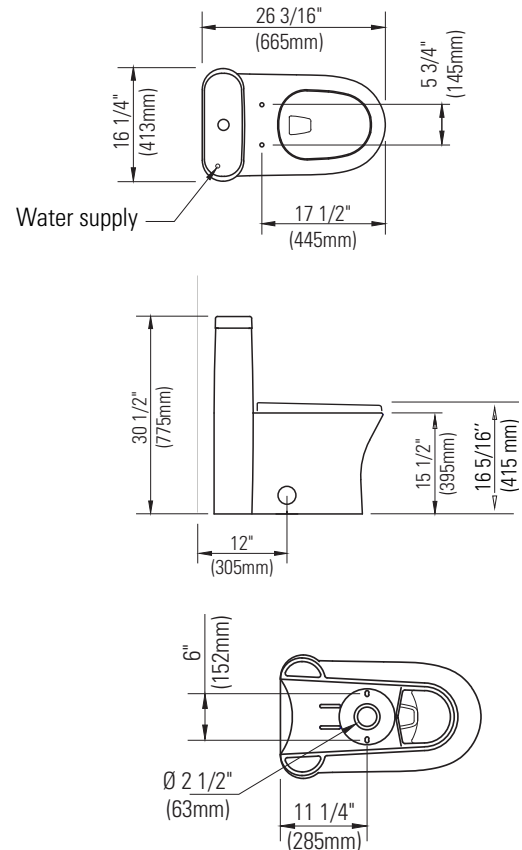

Meets Canadian Standards Association standard B651-04.

\* All dimensions are approximate and subject to change without notice. Please refer to the installation guide before beginning the installation.



Certification **ECORESPONSIBLE**  
 First manufacturer of bathroom products in North America to be certified ecoresponsible.



## Produits Neptune

6835, Picard street, Saint-Hyacinthe (Quebec) J2S 1H3  
 Phone: (450) 773-7058 - Fax: (450) 773-5063  
 produitsneptune.com